

# **HILINE EXPRESS**

4 page Newspaper cum Semi Commercial press

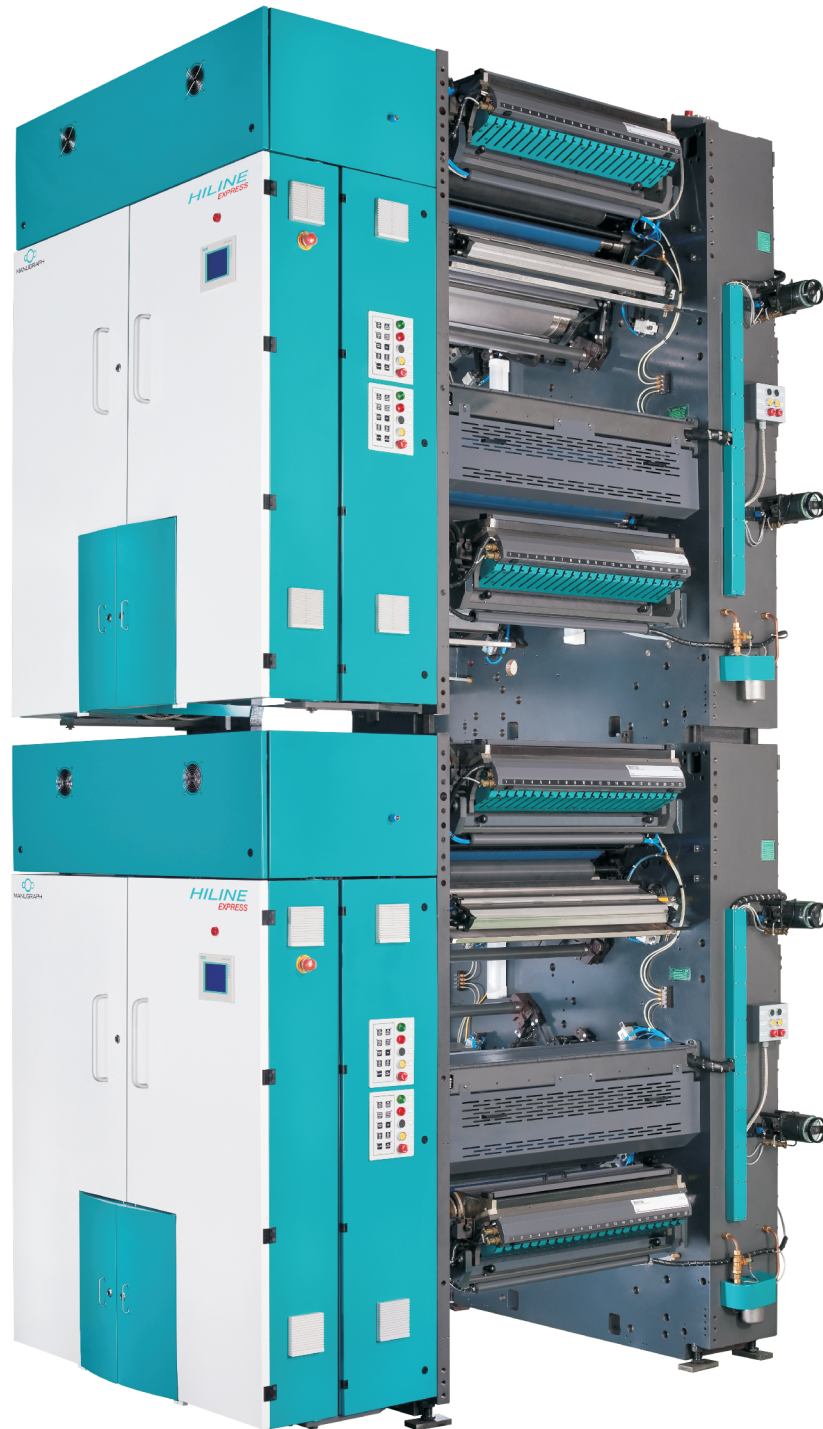

**MANUGRAPH**  
Technology in Print

## Hiline Express : An efficient press for meeting diverse printing requirements

**Hiline Express** is a technical extension – an evolution of the immensely popular **Hiline**. With **Hiline Express**, Manugraph offers a sophisticated product in the range of 4-page Rotary Presses, especially suitable for high-class, quality printing of semi-commercial products **as much as** deadline-oriented newspapers. And all at an economic cost!

With its modular construction of print units, folders and reelstands, **Hiline Express** provides amazing configuration and production possibilities in terms of colour imposition and pagination. And, what is unique about **Hiline Express** and deserves special mention is its **commercial type of ink train technology** : a 10-roller ink train with **3 ink forme rollers** of differing diameters and 3 water-cooled oscillators, complemented by a zone-wise controllable Spray Dampening system. Simply ideal for Newspaper **and** Semi Commercial Printing!

### This technology :

- **Maximizes** print contrast and solid density.
- **Minimizes** dot gain and ghosting.
- Provides **sharp dots** & perfect dot reproduction on mid tones and highlights.

### Why this technology?

With the changing media dynamics in the Newspaper

Industry, a key question for publishers is what additional profits and revenues can be generated by their print products and related print technologies? The answer lies in both revitalizing existing newspaper products and creating new ones that compete. In the process, newspaper establishments have to bring their own print quality closer to the standards of commercial printers. This would assist both investment planning and identify opportunities for increased revenue and diversification. Further it would deliver a higher ROI through a more targeted and personalized approach. Filling idle time is the mantra. Newspapers across the country have realized that while deadline-oriented daily newspapers are printed during the night, the idle day time of the press could also be fully utilized to print high class quality semi-commercial work.

With UV or Heatset package installed, **Hiline Express** becomes the machine of choice for newspaper printers, who also wish to do high class semi-commercial colour work on a wide range of substrates, ranging from standard newsprint to coated paper, including glazed newsprint, SC paper and LWC paper. With **Hiline Express**, Newspaper printers can thus produce colourful inserts, supplements, magazines and brochures, as well as daily newspapers of course. Even hybrid printing is possible.

## Features at a glance

- 50,000 copies per hour.
- Vertical web leads
- Standalone flying splicer
- PIV driven Tension roller with rubber roller nip.
- Toolless plate lock-up.
- Pneumatics for impression, inking/dampening and reel stand brakes.
- Motorised bearer lubrication
- Remote registration and cut off control.
- Motorised dustle wheel control.
- 10 -roller inking system with 3 forme rollers of different diameters; and chilled oscillating rollers
- 3 -roller Spray dampening system.
- Auto tracking of ink duct and water pan roller.
- Web severer at the entry & exit of tower.
- Inertia roller at the tower exit to automatically pull out and wrap up the paper upon web breaks.
- Infrared web break detectors at entry and exit of Tower.
- Variable speed RTF roller.
- Ink silencing system for each ink train.
- Shaftless or shafted drive systems
- Overload protection: Clutch control for shafted presslines and electronic control for shaftless presslines.
- Pneumatic ON-OFF controls for washing device.
- Integrated PLC panel on print unit.
- Choice of jaw folders: F 222 / F1240 / F233.
- PLC based electrical control system..
- ManuColor remote ink zone control system. Option of CIP3 interface / TIFF 1-Bit connectivity.

## Creating a world of possibilities:

### Modular unit designs

The Tower units are of rugged construction with box type sidewall on drive side and plain side wall on operating side and are made from high strength cast iron with ribbed construction. A wide range of unit designs satisfies all requirements of color placement, leading to total flexibility. The space saving design of **Hiline Express** and the high quality components that go into its manufacture are the hallmarks of the machine.

Printing units are available in H and Tower modules with vertical web lead. The 4 high Tower comprises 2H units placed one over the other. This offers high color and page capacities predominantly for newspapers. PLC

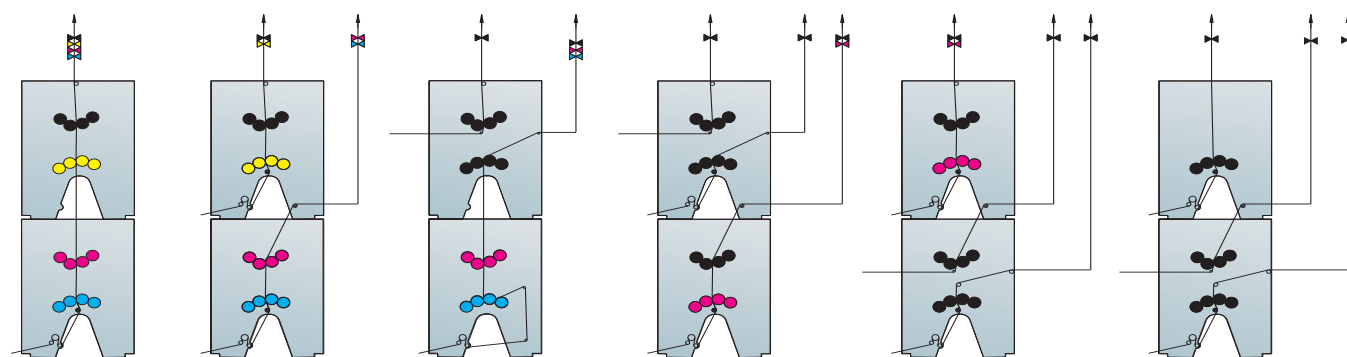

### Hiline Express Print unit modules :

If color pagination is high and back to back 4 colours is a requirement, Tower configuration with its vertical web lead is the most ideal solution. Tower configuration of **Hiline Express** is supported by reliable tension control system, short web paths and anti fan out devices to ensure perfect register.

The H module could either be used for printing 2 webs with 1 colour only back-to-back or a single web with 2 colours back-to-back. Two H units stacked one over the other forms Tower Unit for printing 4x4 colors. The

based electrical controls simplify operation and increase reliability.

**Hiline Express** incorporates a 10-roller ink train consisting of 3 ink form rollers, 3 oscillating rollers with option of water cooling facility, complemented by Spray dampening system. These help produce excellent semi-commercial print quality.

Precisely manufactured gears, world-class bearings and technologies that guarantee constant web tension and perfect registration at top speed are employed. Such features, complemented by short web leads, ensure consistent unit-to-unit registration.

customer can print 4x1, 4x2 colour through the Tower by silencing the idle ink train. Even 3 webs can be run through Tower unit. Web tension control is precise and perfect on **Hiline Express** irrespective of the configuration and modules chosen and the web lengths.

With installation of a heatset package or UV curing system and by providing chilled water to ink oscillating roller, **Hiline Express** can be used as a full-fledged semi commercial press.

### Cylinders for the best performance

The dynamically balanced plate and blanket cylinders are made of solid stainless steel and mounted on pre-loaded bearings. All cylinders have wide and strong bearer rings made of tool steel. The bearers are automatically lubricated.

Plate cylinders have a narrow-slot toolless plate lock-up system, and blanket cylinders have worm and worm wheel type clamping system for quick mounting of blankets. The plate lock-up design facilitates fast and easy plate changes. Register wedge provided in the cylinders ensures quick plate lock-up in true register. Adjustment to circumferential and lateral register is motorized.

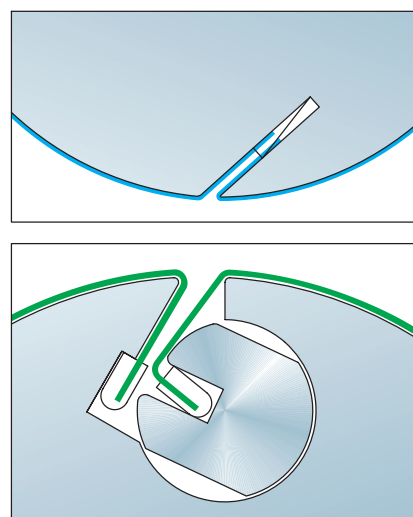

## Sturdy Drive System

**Hiline Express** sports a sturdy drive system. There is a choice of press drive systems: shafted and shaftless. On a conventional drive system, all units are mechanically synchronized with the line shaft. The drive shaft is outside the sidewall and through a compact drive gear box. The engage/disengage operation is via pneumatic clutch with built-in overload protection. In

the shaftless drive system, each H unit has its own AC asynchronous servomotor and drive control, along with built-in overload protection. All motors are electronically synchronized. Drive and electronic components are housed in separate drive panels. Shaftless drives for each stack are also available optionally.

## Inking System

- 10-roller film inking system with undershot precision blade and 3 forme rollers of different diameters with optional chilled water circulation.
- Ink duct roller driven by a separate DC motor having auto-tracking facility with press speed.
- Ink take-up roller, rilsan coated with diamond knurled surface
- Pneumatic ON/OFF facility for the forme rollers
- 3 rilsan coated oscillating rollers having  $\pm 15$  mm fixed oscillating stroke.
- Each ink train equipped with pneumatically operated washing device.
- Dynamically precision - balanced rollers.
- Laser cut ink blade for most accurate zonal ink control
- Entire fountain assembly can be swung away for cleaning & maintenance.
- ManuColor (remote operated) zonal ink key system , optional
- CIP 3 / CIP 4 interface for ManuColor
- Ink silencing system to decouple any ink- train for printing 4/1, 4/2 etc.

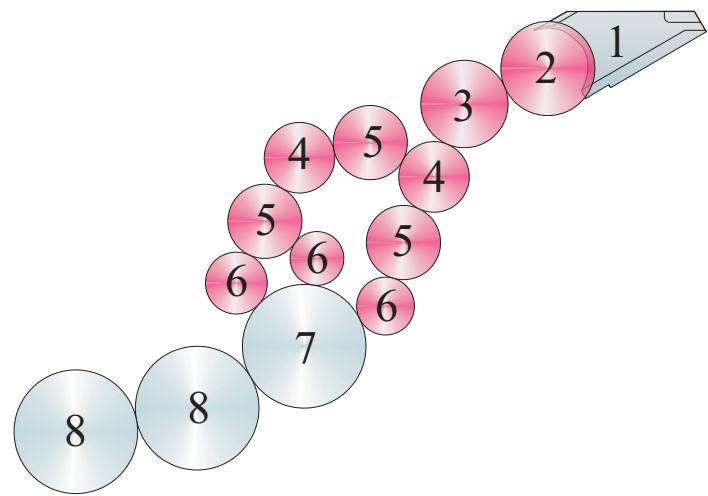

- |                          |                       |
|--------------------------|-----------------------|
| 1. Ink duct              | 2. Duct Roller        |
| 3. Film roller           | 4. Distributor roller |
| 5. Oscillating roller    | 6. Forme roller       |
| 7. Plate cylinder        | 8. Blanket cylinder   |
| 9. Roller washing device |                       |

## Spray Dampening System

- 3- roller Spray dampening system.
- Spray bar function controls from Central console.
- Dedicated touch panel on the central console for controlling all spray bar functions and dampening curve settings , with total flexibility of selection.
- Micron level filtering of dampening solution at chiller level.
- On-line nozzle cleaning.
- Provision of shutters to suit different web widths.
- Centralised water circulating tank having refrigeration facility.

- |                       |                     |
|-----------------------|---------------------|
| 1. Dampening Roller   | 4. Plate cylinder   |
| 2. Oscillating Roller | 5. Blanket Cylinder |
| 3. Forme Roller       | 6. Spray Bar        |

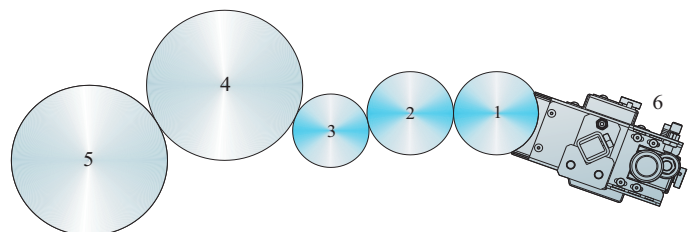

## Folder flexibility for more product versatility

**Hiline Express** offers a choice of 3 rigid folders to suit different product requirements. The standard folder F222 is designed for 6 webs on 2 2 2 principle and delivers 24 pages broadsheet or 48 pages tabloid. For a higher number of webs, F233 jaw folder based on 2:3:3 principle or F1240 is offered. F233 & F1240 folders can take a maximum of 12 webs i.e. a maximum of 48 pages broadsheet or 96 pages tabloid. The F233 & F1240 folders have been specifically designed to provide the necessary folding precision for high pagination products.

There are motorized cut-off compensating rollers on the folder superstructure for every web.

Folders can be offered with optionals like 3rd fold (quarter), parallel fold, and balloon formers. Gluing and stitching attachment also can be offered.

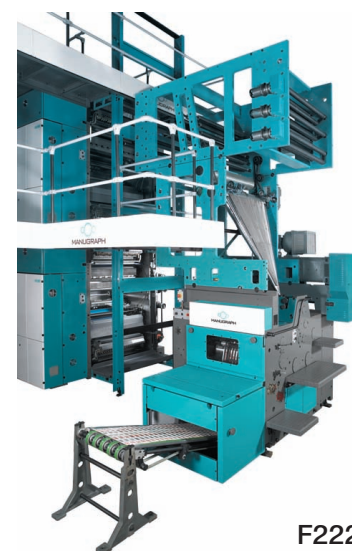

F222

## Features

- Choice of F222, F233 or F1240 rigid jaw folders, for up to 12 webs.
- Variable speed drive on RTF.
- Air cushioned 70° former.
- One or two upper formers for 2 or 3 section products.
- Lap adjustment facility.
- Folding cylinder with diameter increment facility.
- Slitter mechanism for tabloid production.
- Web severer in the folder.
- Electronic multi sheet detection facility.
- Adjustable batch counter.
- Optional attachments :
  - Rotary 3rd (quarter) fold.
  - Double parallel fold for F222 and F233.
  - Upper former (Balloon former).
  - Longitudinal and cross perforation.
  - Gluing & stitching attachment.

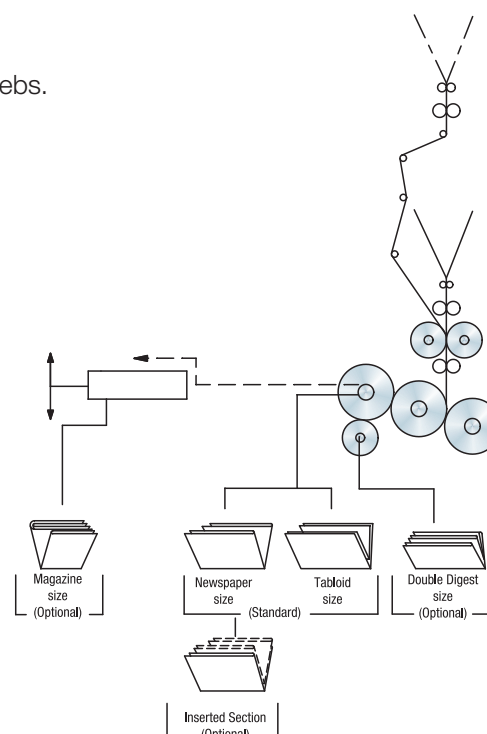

Folding possibilities on a F222 folder

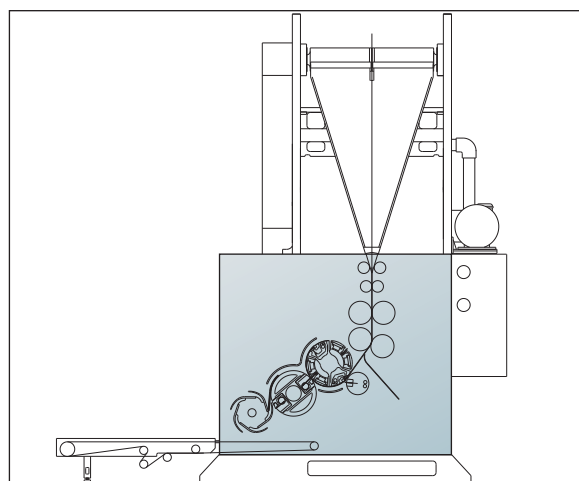

F 1240

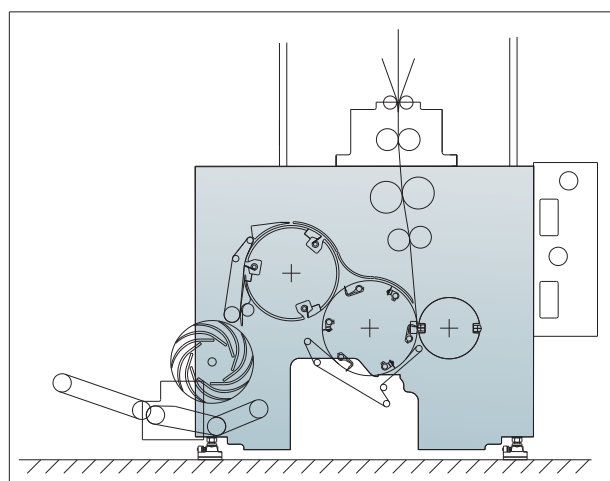

F 233

## Reliable Flying Splicers

**Hiline Express** is offered with the most ideal flying splicers, that are capable of holding 2 full reels, each of 1270 mm. diameter and a maximum reel weight of 1200kgs. The splicers can be placed inline or at right angle( 90°) or even at basement level.

### Technical Specifications

Reel diameter	max.1270 mm (50")
Web width	965 mm
Core diameter	76 mm
Reel weight	max. 1200 Kg
Web speed	max. 11 m/Sec

### Standard features

- Two arm reel splicer capable of holding two full size 50 dia. reels
- Reel loading possible directly from floor
- Reel holding on pneumatically activated lock-up cones, no reel shaft needed
- Motorized accelerating belt for new reel
- Dancing roller with precision electro-pneumatics for close-loop tension and monitoring
- Reel carrying arms with motorized pivoting
- Motorized lateral individual adjustment
- Automatic reel edge alignment before pasting
- Local control panel with touch control, display screen and diagnostics
- Inline, 90° placement or at basement

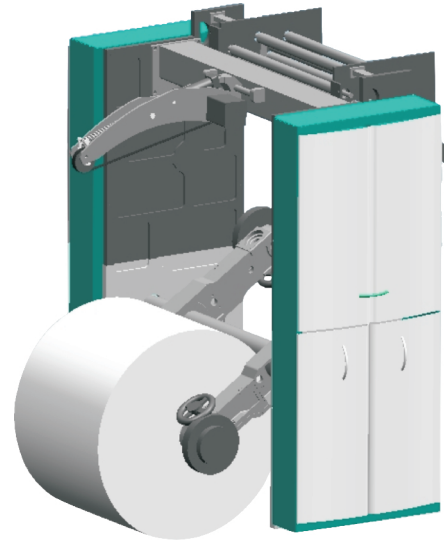

**AP 6050**

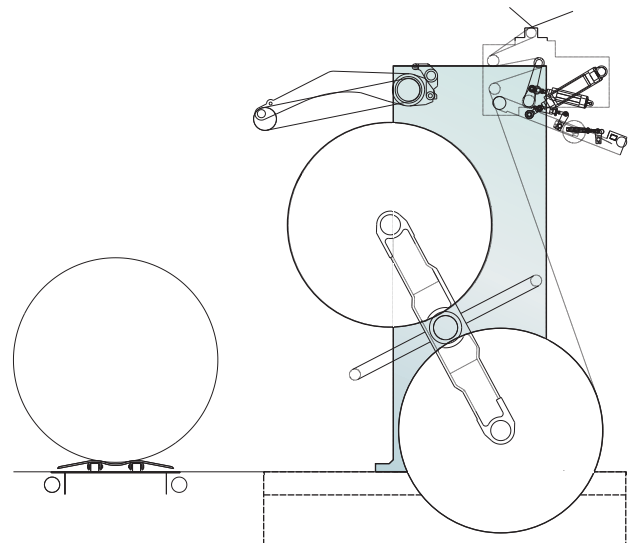

## Total Control

### Electricals, Operating Controls and Drive



All electricals are pre-wired and networked with remote programmable logic controller system. This means less cable route, easy diagnostics and trouble shooting, user friendliness and quick access to individual print units.

### Press controls

#### Basic level module

Each unit and auto paster has its own PLC for all print functions and splicing applications. The touch panel offer different print functions, which are reflected on the central console display as well. At the print unit level, ink duct motor on/off, adjustment of ink water balance, engagement of inking & dampening rollers, manual adjustment of ink keys and web break-detector selections are all possible.

#### Central Console & PLC

There is high-speed network for control between central console and towers. The Central Console has operating switches for all press drive functions, It also has a color touch screen operator interface from where all print units can be accessed and functions controlled, in both auto and manual mode. Each H stack can be engaged / disengaged from the central console. Functions like ink-roller speed adjustment and preprogrammed ink balance

settings can be easily achieved from the touch screen. Spray bar dampening system functions such as nozzle-wise and section-wise control, Tower wise controls and overall base dampener curve selection and overriding are all possible from the dedicated touch panel mounted on the Central console. Basic data such as machine speed, gross copy, net copy, stack functional status are all displayed on the touch screen. The motorized registration, and bustle wheel adjustments are remotely controlled from the touch screen. Fault diagnostics and periodic maintenance guidelines are also displayed. And, optionally all press and register controls can also be integrated with ManuColor, the remote ink control system from Manugraph.

### MANUCOLOR REMOTE INK ZONE CONTROL

ManuColor Remote Ink Zone Control System is developed by Manugraph. It is a standalone system for remote ink zone control with option of CIP3 interface for ink key presetting. Multiple ManuColor Consoles can be configured based on configuration need.

- Separate 15 Inch Touch screen display for Remote Ink Zone Control
- Segmented Blade
- Job Storage
- Multi movement of motors
- Manual override
- Manual calibration
- Self diagnostics
- Individual ~~all~~ zone increase ~~decrease~~
- Locking of control keys
- Group zone increase/decrease
- Job saving ~~pre~~ setting
- Change of color order
- Editing notes

# HILINE EXPRESS

Max. printing speed 2nd fold	50,000 c.p.h.
3rd fold	30,000 c.p.h. to 40,000 c.p.h. depending on the number of webs and folder employed
Max. reel diameter	1270mm (50 inches)
Max. web width	915 mm (36 inches)
Printing unit modules	Mono, H and 4 Hi Tower with vertical web leads; arch & reverse arch architecture
Cut-off length	533, 546, 560, 578 mm (21, 21 <sup>1</sup> / <sub>2</sub> , 22, 22 <sup>3</sup> / <sub>4</sub> inches)
Inking System	10 roller ink train, with 3 forme rollers of differing diameters and 3 oscillators
Dampening System	Spray dampening
Plate mounting	Toolless slot mounting
Flying Splicer / Autopaster	<ul style="list-style-type: none"> <li>AP 6050 (with 2 full reel holding capacity)</li> <li>Placement option – Inline, 90°, basement.</li> </ul>
Choice of Jaw folders	F1240, F233 folders, for upto 12 webs (48 pages broadsheet, 96 pages tabloid) & F222 upto 6 webs.
Data management	PLC based
Optionals	<ul style="list-style-type: none"> <li>Angle bar modules</li> <li>Close loop register and cut off control</li> <li>Centralized ink feeding system with ink level controllers.</li> <li>Water- cooled oscillators.</li> <li>Manucolor remote ink zone control system &amp; CIP3 interface</li> <li>Detachable shaft.</li> <li>Shaftless drive.</li> <li>Upper former (Balloon)</li> <li>Stitching attachment.</li> <li>Quarter Fold</li> <li>Double Parallel fold</li> <li>UV Curing /Heatset drying system</li> </ul>

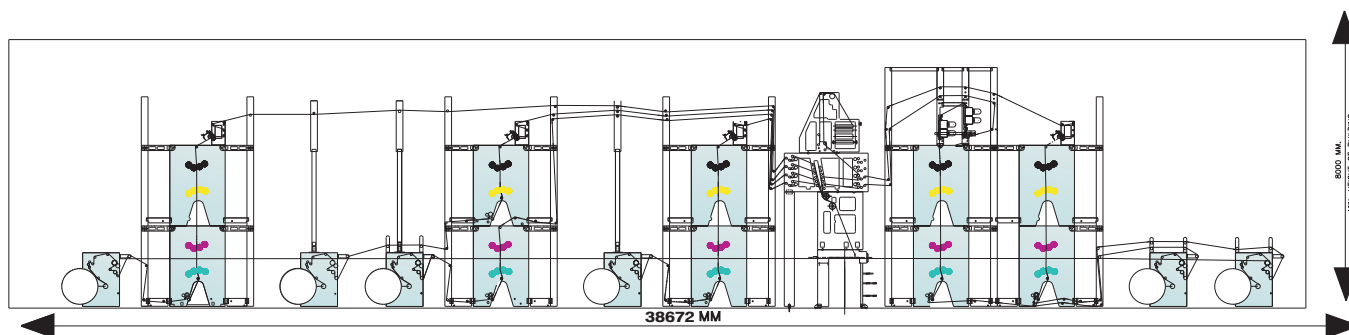

## Manugraph India Ltd.

Sidhwa House, N.A. Sawant Marg, Colaba, Mumbai - 400 005 INDIA.  
 Phone: +91 22 2287 4815/1191 Fax: +91 22 2287 0702  
 E-mail: sales@manugraph.com Website: www.manugraph.com

Hiline Express is subject to continuous upgradation resulting from ongoing research and development and practical experiences gained. Therefore, in the interest of the customers we reserve the right to modify the specifications, features and technical data without notice. Only the specifications while confirming the order shall be binding. HILINE EXPRESS is a registered trademark of Manugraph India Ltd.